

Thomas Tutorials

Date :

NEET - 2016

TEST ID: 01

Time : 03:00:00

PCB

Marks : 720

1. The dimensions of a rectangular block measured with calipers having least count of 0.01 cm are 5 mm × 10 mm × 5 mm. The maximum percentage error in the measurement of the volume of the block is
 a) 5% b) 10% c) 15% d) 20%
2. If $S = \frac{1}{3}ft^3$, f has the dimensions of
 a) $[M^0L^{-1}T^3]$ b) $[MLT^{-3}]$
 c) $[M^0L^1T^{-3}]$ d) $[M^0L^{-1}T^{-3}]$
3. Which of the following are true?
 (i) A body having constant speed can have varying velocity.
 (ii) Position-time graphs for two objects with zero relative velocity are parallel.
 (iii) The numerical ration of velocity to speed of an object can never be more than one.
 a) (i) b) (ii) and (iii)
 c) All d) None of these
4. A particle is projected from the ground with an initial speed of v at an angle θ with horizontal. The average velocity of the particle between its point of projection and highest point of trajectory is
 a) $\frac{v}{2}\sqrt{1+2}$ b) $\frac{v}{2}\sqrt{1+c}$ c) $\frac{v}{2}\sqrt{1+3}$ d) $v \cos \theta$
5. A fighter plane enters inside the enemy territory, at time $t = 0$ with velocity $v_0 = 250 \text{ ms}^{-1}$ and moves horizontally with constant acceleration $a = 20\text{ms}^{-2}$ (see figure). An enemy tank at the border, spot the plane and fire shots at an angle $\theta = 60^\circ$ with the horizontal and with velocity $u = 600 \text{ ms}^{-1}$. At

what altitude H of the plane it can be hit by the shot?

- a) $1500\sqrt{3}\text{m}$
 - b) 125 m
 - c) 1400 m
 - d) 2473 m
6. A train is moving with velocity 20 m/s on this dust is falling at the rate 50kg/min. The extra force requested to move this train with a constant velocity will be
 a) 16.66 N b) 1200 N c) 1000 N d) 166.6 N
 7. In the figure, the ball A is released from rest when the spring is at its natural length. For the block B of mass M to leave contact with the ground at same stage, the minimum mass of A must be

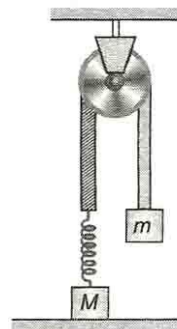

- a) $2M$
 - b) M
 - c) $\frac{M}{2}$
 - d) spring
- A function of M and the force constant of the

8. If F is the force required to keep a train moving at a constant speed v , the power required is
 a) $\frac{1}{2}Fv^2$ b) Fv^2 c) $\frac{1}{2}Fv$ d) Fv
9. A body rolls down an inclined plane. If its kinetic energy of rotation is 40% of its kinetic energy of translation, then the body is
 a) Solid cylinder b) Solid sphere
 c) Disc d) Ring
10. A gramophone turn table rotating at 75 rpm slow down uniformly and stops in 5 s after the motor is turned off. Its angular acceleration (rad s^{-2})
 a) -0.42 b) -0.89 c) -1.57 d) -1.96
11. A body is released from a point distance r from the centre of earth. If R is the earth and $r > R$, then the velocity of the body at the time of striking the earth will be
 a) \sqrt{gR} b) $\sqrt{2gR}$
 c) $\sqrt{\frac{2gR}{r-R}}$ d) $\sqrt{\frac{2gR(r-R)}{r}}$
12. Two wires of the same material and length are stretched by the same force. Their masses are in the ratio 3:2. Their elongations are in the ratio
 a) 3 : 2 b) 9 : 4 c) 2 : 3 d) 4 : 9
13. Three capillaries of length L , $L/2$ and $L/3$ are connected in series. Their radii are r , $r/2$ and $r/3$ respectively. Then, if stream-line flow is to be maintained and the pressure across first capillary is p , then the
 a) pressure difference across the end of second capillary is $8p$
 b) pressure difference across the third capillary is $43p$
 c) pressure difference across the end of second capillary is $16p$
 d) pressure difference across the third

capillary is $56p$

14. A log of wood of mass 120 kg floats in water. The weight that can be put on raft to make it just sink, should be (density of wood = 600 kg/m^3)
 a) 80 kg b) 50 kg c) 60 kg d) 30 kg
15. Two identical rods of copper and iron are coated with wax uniformly. When one end of each is kept at temperature of boiling water, the length upto which wax melts are 8.4 cm and 4.2 cm respectively. If thermal conductivity of copper is 0.92 , then thermal conductivity of iron is
 a) 0.23 b) 0.46 c) 0.115 d) 0.69
16. During an adiabatic process, the cube of the pressure is found to be inversely proportional to the fourth power of the volume. Then the ratio of specific heats is
 a) 1 b) 1.33 c) 1.67 d) 1.4
17. When a system is taken from state i to state f along the path iaf , it is found that $Q=50 \text{ cal}$ and $W=20 \text{ cal}$. Along the path ibf , $Q=36 \text{ cal}$. W along the path ibf is

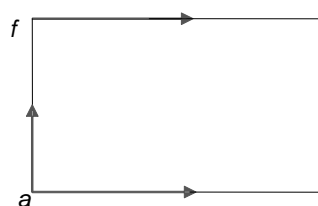

- a) 6 cal b) 16 cal c) 66 cal d) 14 cal
18. S.I. unit of universal gas constant is
 a) $\text{cal}/^\circ\text{C}$ b) J/mol
 c) $\text{J mol}^{-1}\text{K}^{-1}$ d) J/kg
19. Two identical balls A and B each of mass 0.1 kg are attached to two identical massless springs. The spring mass system is constrained to move inside a rigid smooth pipe bent in the form of circle as shown in the figure. The pipe is fixed in a horizontal plane. The centres of

the balls can move in a circle of radius 0.06 m . Each spring has a natural length of $0.06\pi\text{ m}$ and force constant 0.1 N/m . Initially both the balls are displaced by an angle $\theta = \pi/6$ radian with respect to the diameter PQ of the circle and released from rest. The frequency of oscillation of the ball B is

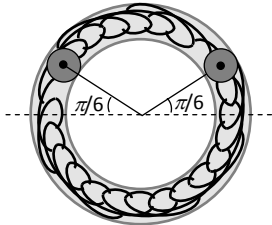

- a) $\pi\text{ Hz}$ b) $\frac{1}{\pi}\text{ Hz}$ c) $2\pi\text{ Hz}$ d) $\frac{1}{2\pi}\text{ Hz}$

20. Two identical springs of constant K are connected in series and parallel as shown in figure. A mass m is suspended from them. The ratio of their frequencies of vertical oscillations will be

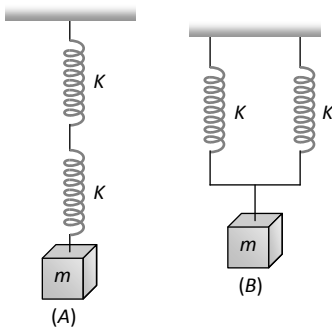

- a) 2 : 1 b) 1 : 1 c) 1 : 2 d) 4 : 1
21. To increase the frequency from 100 Hz to 400 Hz the tension in the string has to be changed by
- a) 4 times b) 16 times
c) 20 times d) None of these
22. Two point charges $-q$ and $+q$ are located at points $(0,0 - a)$ and $(0,0 a)$, respectively. The potential at a point $(0,0, z)$ where $z > a$ is
- a) $\frac{qa}{4\pi\epsilon_0 z^2}$ b) $\frac{q}{4\pi\epsilon_0 a}$
c) $\frac{2qa}{4\pi\epsilon_0 (z^2 - a^2)}$ d) $\frac{2qa}{4\pi\epsilon_0 (z^2 + a^2)}$

23. The relation between the intensity of the electric field of an electric dipole at a distance r from its centre on its axis and the distance r is where ($r \gg 2l$)

- a) $E \propto \frac{1}{r}$ b) $E \propto \frac{1}{r^2}$
c) $E \propto \frac{1}{r^4}$ d) $E \propto \frac{1}{r^3}$

24. What is the potential difference between points A and B in the circuit shown?

- a) 2 V b) 4 V c) 3 V d) 12 V

25. How much work is required to carry a $6\text{ }\mu\text{C}$ charge from the negative terminal to the positive terminal of a 9 V battery

- a) $54 \times 10^{-3}\text{ J}$ b) $54 \times 10^{-6}\text{ J}$
c) $54 \times 10^{-9}\text{ J}$ d) $54 \times 10^{-12}\text{ J}$

26. The internal resistance of a cell of e.m.f. 12 V is $5 \times 10^{-2}\Omega$. It is connected across an unknown resistance. Voltage across the cell, when a current of 60 A is drawn from it, is

- a) 15 V b) 12 V c) 9 V d) 6 V

27. There are three voltmeters of the same range but of resistances 10000Ω , 8000Ω and 4000Ω respectively. The best voltmeter among these is the one whose resistance is

- a) 10000Ω b) 8000Ω
c) 4000Ω d) All are equally good

28. A stream of electrons is projected horizontally to the right. A straight conductor carrying a current is supported parallel to electron stream and above it. If the current in the

conductor is from left to right, then what will be the effect on electron stream?

- a) The electron stream will be speeded up towards the right
 b) The electron stream will be retarded
 c) The electron stream will be pulled upward
 d) The electron stream will be pulled downward
29. At a certain place, the angle of dip is 30° and the horizontal component of earth's magnetic field is 0.50 oersted. The earth's total magnetic field (in oersted) is
 a) $\sqrt{3}$ b) 1 c) $\frac{1}{\sqrt{3}}$ d) $\frac{1}{2}$
30. Consider a short magnetic dipole of magnetic length 10 cm. Its geometric length is
 a) 12 cm b) 8 cm c) 10 cm d) 14 cm
31. A uniformly wound solenoid coil of self-inductance $1.8 \times 10^{-4} \text{H}$ and resistance 6Ω is broken up into two identical coils. These identical coils are then connected in parallel across a 12 V battery of negligible resistance. The time constant for the current in the circuit is
 a) $0.1 \times 10^{-4} \text{s}$ b) $0.2 \times 10^{-4} \text{s}$
 c) $0.3 \times 10^{-4} \text{s}$ d) $0.4 \times 10^{-4} \text{s}$
32. The frequency of ac mains in India is
 a) 30 c/s or Hz b) 50 c/s or Hz
 c) 60 c/s or Hz d) 120 c/s or Hz
33. In the circuit shown in figure switch S is closed at time $t = 0$. The charge which passes through the battery in one time constant is

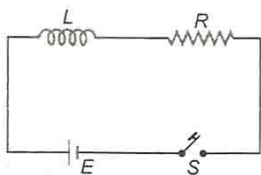

- a) $\frac{EL}{eR^2}$
 b) $\frac{eL}{ER}$

c) $\frac{eR^2E}{L}$

d) $E\left(\frac{L}{R}\right)$

34. Radiations of intensity 0.5Wm^{-2} are striking a metal plate. The pressure on the plate is
 a) $0.166 \times 10^{-8} \text{Nm}^{-2}$ b) $0.332 \times 10^{-8} \text{Nm}^{-2}$
 c) $0.111 \times 10^{-8} \text{Nm}^{-2}$ d) $0.083 \times 10^{-8} \text{Nm}^{-2}$
35. A plane mirror makes an angle of 30° with horizontal. If a vertical ray strikes the mirror, find the angle between mirror and reflected ray
 a) 30° b) 45° c) 60° d) 90°
36. A thin equiconvex lens of refractive index $\frac{3}{2}$ and radius of curvature 30 m is put in water (refractive index $=\frac{4}{3}$). Its focal length is
 a) 0.15 m
 b) 0.30 m
 c) 0.45 m
 d) 1.20 m
37. A mixture of light, consisting of wavelength 590 nm and an unknown wavelength, illuminates Young's double slit and gives rise to two overlapping interference patterns on the screen. The central maximum of both lights coincide. Further, it is observed that the third bright fringe of known light coincides with the 4th bright fringe of the unknown light. From this data, the wavelength of the unknown light is
 a) 393.4 nm b) 885.0 nm
 c) 442.5 nm d) 776.8 nm
38. The potential energy of a particle of mass m is given by

$$U(x) = \begin{cases} E_0; & 0 \leq x \leq 1 \\ 0; & x > 1 \end{cases}$$
 λ_1 and λ_2 are the de-Broglie wavelengths of the particle, when $0 \leq x \leq 1$ and $x >$

- 1 respectively. If the total energy of particle is $2E_0$, the ratio $\frac{\lambda_1}{\lambda_2}$ will be
- a) 2 b) 1 c) $\sqrt{2}$ d) $\frac{1}{\sqrt{2}}$
39. The minimum light intensity that can be perceived by the eye is about 10^{10} Wm^{-2} . The number of photons of wavelength $5.6 \times 10^{-7} \text{ m}$ that must enter the pupil of area $10^{-4} \text{ m}^2 \text{ s}^{-1}$, for vision is approximately equal to ($h = 6.6 \times 10^{-34} \text{ J-s}$)
- a) 3×10^2 photons b) 3×10^3 photons
c) 3×10^4 photons d) 3×10^5 photons
40. Hydrogen atoms are excited from ground state of the principal quantum number 4. Then the number of spectral lines observed will be
- a) 3 b) 6 c) 5 d) 2
41. If R is the Rydberg's constant for hydrogen the wave number of the first line in the Lyman series will be
- a) $\frac{R}{4}$ b) $\frac{3R}{4}$ c) $\frac{R}{2}$ d) $2R$
42. In hydrogen atom, electron makes transition from $n = 4$ to $n = 1$ level. Recoil momentum of the H atom will be
- a) $3.4 \times 10^{-27} \text{ N-s}$ b) $6.8 \times 10^{-27} \text{ N-s}$
c) $3.4 \times 10^{-24} \text{ N-s}$ d) $6.8 \times 10^{-24} \text{ N-s}$
43. In a $n-p-n$ transistor 10^{10} electrons enter the emitter in 10^{-6} s . 4% of the electrons are lost in base. The current transfer ratio will be
- a) 0.98 b) 0.97 c) 0.96 d) 0.94
44. If an electromagnetic wave is transmitted to the height equal to 150 km with maximum frequency 300 kHz and critical frequency 100 kHz, the skip distance is
- a) 426 km b) 636 km c) 824 km d) 849 km
45. The modulation in which pulse duration varies in accordance with the modulating signal is called
- a) PAM b) PPM c) PWM d) PCM
46. The number of water molecules in 1 L of water is
- a) $18 N_A$ b) $18 \times 1000 N_A$ c) N_A d) $55.55 N_A$
47. A sample of a mixture of CaCl_2 and NaCl weighing 4.22 g was treated to precipitate all the Ca as CaCO_3 . This CaCO_3 is then heated and quantitatively converted into 0.959 g of CaO . Calculate the percentage of CaCl_2 in the mixture. (Atomic mass of $\text{Ca} = 40, \text{O} = 16, \text{C} = 12$ and $\text{Cl} = 35.5$)
- a) 31.5% b) 21.5% c) 45.04% d) 68.48%
48. Which of the following is Heisenberg uncertainty principle?
- a) $\Delta x. \Delta p \geq \frac{h}{4\pi}$ b) $\Delta x. \Delta p = \frac{h}{4\pi}$
c) $\Delta x. \Delta p \leq \frac{h}{4\pi}$ d) $\Delta x. \Delta p < \frac{h}{4\pi}$
49. The lightest particle is
- a) α -particle b) Positron
c) Proton d) Neutron
50. The correct order of decreasing first ionisation energy is
- a) $\text{C} > \text{B} > \text{Be} > \text{Li}$ b) $\text{C} > \text{Be} > \text{B} > \text{Li}$
c) $\text{B} > \text{C} > \text{Be} > \text{Li}$ d) $\text{Be} > \text{Li} > \text{B} > \text{C}$
51. Structure of ammonia is
- a) Pyramidal b) Tetrahedral
c) Trigonal d) Trigonal pyramidal
52. Compound X is anhydride of sulphuric acid. The number of σ bonds and the number of π - bonds present in X are, respectively.
- a) 3, 3 b) 4, 2
c) 2, 4 d) 4, 3
53. Frenkel defect is found in crystals in which the radius ratio is
- a) 1.5
b) 1.7
c) Very low

- d) Slightly less than unity
54. Heat of combustion of a substance:
- Is always positive
 - Is always negative
 - Is equal to heat of formation
 - Nothing can be said without reaction
55. Molar heat of vaporisation of a liquid is 6 kJ mol^{-1} . If the entropy change is $16 \text{ J mol}^{-1}\text{K}^{-1}$, the boiling point of the liquid is
- 375°C
 - 375 K
 - 273 K
 - 102°C
56. Formation of SO_3 from SO_2 and O_2 is favoured by
- Increase in pressure
 - Decrease in pressure
 - Increase in temperature
 - Decrease in temperature
57. Which is the best description of behaviour of bromine in the reaction given below?
- $$\text{H}_2\text{O} + \text{Br}_2 \rightarrow \text{HBr} + \text{HOBr}$$
- Proton accepted only
 - Both oxidised and reduced
 - Oxidised only
 - Reduced only
58. The oxidation state of sulphur in sodium tetrathionate ($\text{Na}_2\text{S}_4\text{O}_6$) is
- 2
 - 0
 - 2.5
 - 3.5
59. The hardness of water is estimated by
- EDTA method
 - Titrimetric method
 - Conductivity method
 - Distillation method
60. Pick out the statement (s) which is (are) not true about the diagonal relationship of Li and Mg.
- Polarising powers of Li^+ and Mg^{2+} are almost same.
 - Like Li, Mg decomposes water very fast.
 - LiCl and MgCl_2 are deliquescent.
 - Like Li, Mg does not form solid

bicarbonates.

- (i) and (ii)
 - (ii) and (iii)
 - Only (ii)
 - Only (i)
61. The colour of blue glass is due to the presence of oxide of
- Cr
 - Co
 - Au
 - Ag
62. Red lead is an example of a/an...oxide
- Basic
 - Mixed
 - Super
 - Amphoteric
63. Among the following the strongest nucleophile is
- $\text{C}_2\text{H}_5\text{SH}$
 - CH_3COO^-
 - CH_3NH_2
 - NCCH_2^-
64. The final product in following sequence of reaction is
- $$\text{CH} \equiv \text{CH} \xrightarrow{\text{NaNH}_2} \text{A} \xrightarrow{\text{CH}_3\text{Br}} \text{B}$$
- $\text{CH}_2 = \text{CH} - \text{CH} = \text{CH}_2$
 - $\text{HC} \equiv \text{C} - \text{CH}_3$
 - $\text{CH}_2 = \text{CH} - \text{CH}_3$
 - $\text{CH}_3 - \text{CH}_2 - \text{CH}_3$
65. Which compound does not give precipitate with ammoniacal silver nitrate solution?
- $\text{C}_2\text{H}_5 - \text{C} \equiv \text{CH}$
 - $\text{CH}_3 - \text{C} \equiv \text{C} - \text{CH}_3$
 - $\begin{array}{c} \text{CH}_3 \\ | \end{array}$
 - $\text{CH}_3 - \text{CH} - \text{C} \equiv \text{CH}$
66. Gas released during Bhopal tragedy was
- Methyl isocyanate
 - Potassium isothiocyanate
 - Sodium isothiocyanate
 - Ethyl isothiocyanate
67. Which kind of defect is shown by the given crystal?
- $$\text{K}^+ \text{Cl}^- \text{K}^+ \text{Cl}^- \text{K}^+ \text{Cl}^-$$
- $$\text{Cl}^- \square \text{Cl}^- \text{K}^+ \square \text{K}^+$$
- $$\text{K}^+ \text{Cl}^- \square \text{Cl}^- \text{K}^+ \text{Cl}^-$$



- a) Schottky defect
b) Frenkel defect
c) Schottky and Frenkel defects
d) Substitution disorder
68. Which one of the following defects in the crystals lowers its density?
a) Frenkel defect b) Schottky defect
c) F-centres d) Interstitial defect
69. A solution is prepared by dissolving 24.5 g of sodium hydroxide in distilled water to give 1L solution. The molarity of NaOH in the solution is
(Given, that molar mass of NaOH = 40.0 g mol^{-1})
a) 0.2450 M b) 0.6125 M
c) 0.9800 M d) 1.6326 M
70. The solubility of a gas increases in a liquid with
a) Decrease in temperature
b) Increases in temperature
c) Reduction of gas pressure
d) Amount of liquid taken
71. Which of the following reactions cannot be a base for electrochemical cell?
a) $\text{H}_2 + \text{O}_2 \rightarrow \text{H}_2\text{O}$
b) $\text{AgNO}_3 + \text{Zn} \rightarrow \text{Zn}(\text{NO}_3)_2 + \text{Ag}$
c) $\text{AgNO}_3 + \text{NaCl} \rightarrow \text{AgCl} \downarrow + \text{NaNO}_2$
d) $\text{KMnO}_4 + \text{FeSO}_4 + \text{H}_2\text{SO}_4 \rightarrow \text{K}_2\text{SO}_4 + \text{Fe}_2(\text{SO}_4)_3 + \text{MnSO}_4 + \text{H}_2\text{O}$
72. Half-life of two samples is 0.1 and 0.8 s. Their respective concentration is 400 and 50 respectively.
The order of reaction is
a) 0 b) 2 c) 1 d) 4
73. The rate for the reaction, $\text{RCl} + \text{NaOH}(\text{aq}) \rightarrow \text{ROH} + \text{NaCl}$ is given by rate = $k[\text{RCl}]$, the freezing point of the reaction is
a) Unaffected by increasing the temperature of the reaction
b) Decreased on increasing the temperature of the reaction
c) Halved on reducing the concentration of RCl to half
d) Doubled on doubling the concentration of NaOH
74. Which of the following is not a property of colloidal solution?
a) Heterogeneity
b) Particle size > 100 nm
c) Tyndall effect
d) Brownian movement
75. A metal which is refined by poling is
a) Silver b) Sodium
c) Blister copper d) Zinc
76. The froth-floatation process is based upon
a) The difference in the specific gravity of ore and gangue particles
b) The magnetic properties of gangue and ore
c) Preferential wetting of gangue particles by oil
d) The solubility of ore particles in suitable reagent
77. Nitrogen dioxide
a) Does not dissolve in water
b) Dissolves in water forming nitric acid
c) Dissolves in water to form a mixture of nitrous and nitric acid
d) Dissolves in water to form nitrous acid and gives off oxygen
78. In context of the lanthanoids, which of the following statements is not correct?
a) There is a gradual decrease in the radii of the members with increasing atomic number in the series.
b) All the members exhibit +3 oxidation state.
c) Because of similar properties the separation of lanthanoids is not easy.
d) Availability of 4f-electrons results in the

formation of compounds in +4 state for all members of the series.

79. Among Sc(III), Ti(IV), Pd(II) and Cu(II) ions

- a) All are paramagnetic
- b) All are diamagnetic
- c) Sc (III), Ti (IV) are paramagnetic and Pd(II), Cu(II) are diamagnetic
- d) Sc (III), Ti (IV) are diamagnetic and Pd(II), Cu(II) are paramagnetic

80. Which of the following is/are threo isomers?

- a) Only (i)
- b) Only (ii)
- c) Only (iii)
- d) All (i), (ii) and (iii)

81. Wurtz's reaction involves the reduction of alkyl halide with

- a) Zn/HCl
- b) HI
- c) Zn/Cu couple
- d) Na in ether

82. In the reaction,

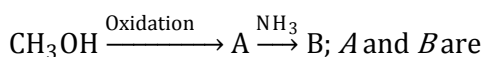

- a) HCHO, HCOONH₄
- b) HCOOH, HCOONH₄
- c) HCOOH, HCONH₂
- d) HCHO, HCONH₂

83. The end product of which of the following reaction is isomer of alcohols?

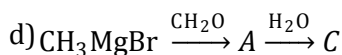
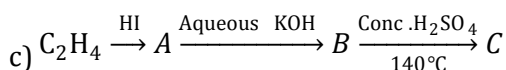
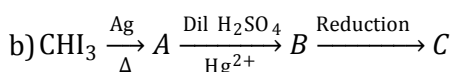
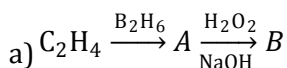

84. When CH₃COOH reacts with CH₃ - MgX

- a) CH₃COX is formed
- b) Hydrocarbon is formed

c) Acetone is formed

d) Alcohol is formed

85. Acetonitriles on hydrolysis produce which of the following?

- a) Amine
- b) Acid
- c) Amides
- d) Carbonyl compounds

86. During diazotization of benzenamine with sodium nitrite and hydrochloric acid, the excess of hydrochloric acid is used primarily to

- a) Check the hydrolysis of φ - OH
- b) Ensure a stoichiometric amount of nitrous acid
- c) Check the concentration of free aniline
- d) Neutralize any base formed during reaction

87. When glucose reacts with bromine water the main product is

- a) Acetic acid
- b) Saccharic acid
- c) Glyceraldehydes
- d) Gluconic acid

88. Bakelite is an example of

- a) Elastomer
- b) Fibre
- c) Thermoplastic
- d) Thermosetting polymer

89. The polymer melmac is obtained by

- a) Addition polymerization of melamine and formaldehyde
- b) Free radical polymerisation of acrylonitrile
- c) Condensation polymerization of melamine and formaldehyde
- d) Coordination polymerisation of melamine

90. Which of the following statement is not true about the drug barbital?

- a) It causes addiction
- b) It is a non-hypnotic drug
- c) It is tranquillizer
- d) It is used insleeping pills

91. Which one is the important function of botanical garden?
- Allow *ex situ* conservation of germplasm
 - Are place for recreation
 - Plant diversity can be observed
 - Provide natural habitat for wildlife
92. A place where dried, pressed and preserved plant specimens are kept
- Herbarium
 - Museum
 - Botanical garden
 - Both (a) and (c)
93. A defining property or characteristic of living organisms is
- Increase in mass
 - Development
 - Response to external stimuli
 - Growth
94. Halophilic archaebacterium, *eg, Halobacterium salinarum* found in great salt lake and dead sea cannot live in
- Less than 3M NaCl concentration
 - Less than 5M NaCl concentration
 - More than 4M NaCl concentration
 - More than 3M NaCl concentration
95. Which one of the following is a matching pair of certain organism (s) and the kind of association?
- Shark and sucker fish – Commensalism
 - Algae and fungi in lichens – Mutualism
 - Orchids growing of trees – Parasitism
 - Cuscuta* (dodder) growing – Epiphytism
On other flowering plants
96. The body structure of green algae may be
- Colonial
 - Unicellular
 - Filamentous
 - All of these
97. The number of prothallial cells in male gametophyte of *Pinus* is
- 2
 - 1
 - 3
 - 0
98. Chitin as exoskeleton is found in
- Periplaneta*
 - Ascaris*
 - Pheretima*
 - Hydra*
99. Different colours of frog skin are controlled by
- Hormones
 - Melanocytes
 - Nervous system
 - Both (a) and (c)
100. The organs that assists in sound production in mosquito, is
- Hairy appendages
 - Mouth parts
 - Hemelytra
 - Halteres
101. Which one of the following families has unicolour superior ovary?
- Asteraceae
 - Solanaceae
 - Papaveraceae
 - Cucurbitaceae
102. The main function (s) of root is
- Absorption of water and minerals
 - To provide proper anchorage of plant
 - To store reserve food
 - All of the above material and synthesis of plant growth regulators
103. Which one of the following statements is correct?
- Seeds of orchids have oil-rich endosperm
 - Placentation in primrose is basal
 - Flower of tulip is a modified shoot
 - In tomato, fruit is a capsule
104. The number of stomata present per cm² of a leaf is
- 1000
 - Less than 100
 - One million
 - None of these
105. Cambium is present in between
- Phloem and xylem
 - Permanent mature cells
 - Collenchyma and sclerenchyma
 - Collenchyma and parenchyma

106. Border parenchyma or bundle sheath is made up of
- Parenchymatous cell
 - Sclerenchymatous cell
 - Chlorenchymatous cell
 - All of these
107. Lymphoid tissue is found in
- Thymus
 - Tonsils
 - Lymph nodes
 - All of these
108. In frog, a solid muscular organ situated in the upper part of the body cavity is
- Heart
 - Intestine
 - Lungs
 - Kidney
109. The length of DNA molecule greatly exceeds the dimensions of the nucleus in eukaryotic cells. How is this DNA accommodated?
- Deletion of non-essential genes
 - Super-coiling in nucleosomes
 - DNA se digestion
 - Through elimination of repetitive DNA
110. In DNA of certain organisms, guanine constitutes 20% of the bases. What percentage of the bases would be adenine?
- 0%
 - 10%
 - 20%
 - 30%
111. Sucrose, a common table sugar is composed of
- Glucose and fructose
 - Glucose and galactose
 - Fructose and galactose
 - None of the above
112. Pepsin is anenzyme
- Intracellular
 - Extracellular
 - Both (a) and (b)
 - None of these
113. Which of the following statements are correct for meiosis?
- I. Meiosis is a double division. It gives rise to

- four cells
- II. The cells undergoing meiosis may be haploid or diploid
- III. No bouquet stage is recorded
- IV. Pairing or synapsis of homologous chromosomes takes place during zygotene of prophase-I and continues upto metaphase-I
- Option containing correct statement is
- I only
 - I and IV
 - II and III
 - All of these
114. 'XX' is a phase of mitosis, in which the chromatin condenses into discrete chromosomes. During 'XX' phase, nuclear envelope breaks down and spindles forms at opposite ends of the cell
- Identify 'XX'
- Interphase
 - Anaphase
 - Telophase
 - Prophase
115. Plants growing on hills are likely to show
- Higher rates of transpiration
 - Lower rates of transpiration
 - Same rate of transpiration as in plains
 - Lower rates of transpiration provided the stomata are sunken
116. The value of osmotic potential of an electrolyte is always
- More than the electrolyte
 - Less than the electrolyte
 - Same as the electrolyte
 - None of these
117. Which statement can be shared by facilitated diffusion and active transport?
- Both need carrier transporter, which are sensitive to inhibitors that reacts with protein side chains
 - Energy is required by both the processes
 - No energy expenditure in these processes
 - Both use carbohydrates to move molecules across the membrane

II. Lifting up of the ribs

III. Sternum causing an increase in the volume of the thoracic chamber in dorsoventral axis

IV. Contraction of the diaphragm which increases the volume of the thoracic chamber in antero-posterior axis

Choose the correct option

- a) I → II → III → IV b) IV → I → II → III
c) IV → I → III → II d) I → III → IV → II

130. How much amount of air can be inspired or expired during normal breathing?

- a) 0.5L b) 2.5L c) 1.5L d) 5.5L

131. Which one has the thickest wall?

- a) Right auricle b) Right ventricle
c) Left auricle d) Left ventricle

132. Refer the statements

I. Carbonic anhydrase is present in the erythrocytes.

II. In erythrocytes, the carbon dioxide combines with water and is transported.

- a) Statement I is correct and is responsible for statement II
b) Statement I is not correct but statement II is correct
c) Both statements I and II are wrong
d) Statement I is correct but not involved in statement II

133. If Henle's loop were absent from mammalian nephron, which of the following is to be expected?

- a) The urine will be more concentrated
b) The urine will be more dilute
c) There will be no urine formation
d) There will be hardly any change in the quality and quantity of urine formed

134. ANF mechanism checks on

- a) Oxytocin – renin mechanism
b) Counter – current mechanism
c) Renin – angiotensin mechanism

d) Oxytocin – angiotensin mechanism

135. Choose the correct order of urine formation in human

- a) PCT → ALH → DLH → DCT → CD
b) ACH → DLH → PCT → DCT → CD
c) PCT → DLH → ALH → DCT → CD
d) CD → DCT → ACH → DLH → PCT

136. In the centre of each I-band there is an elastic fibre called

- a) I-line b) Z-line c) A-line d) H-zone

137. Bones of the limbs along with their girdles constitutes the

- a) Appendicular skeleton b) Axial skeleton
c) Apex skeleton d) Axis skeleton

138. Synsacrum of fowl consists of about

- a) 29 vertebrae b) 3 vertebrae
c) 16 vertebrae d) Single vertebrae

139. Synaptic vesicles contains chemicals called

- a) Synaptic fluid b) Neurotransmitters
c) Vesicular fluid d) All of these

140. Choose the correct non-protein amino acid from the given option.

- a) Hydroxyproline
b) Hydroxylysine
c) Cystine
d) γ -amino butyric acid

141. Which of the following is a mineralocorticoid?

- a) Testosterone b) Progesterone
c) Adrenaline d) Aldosterone

142. Cholecystokinin is secreted by

- a) Large intestine b) Small intestine
c) Liver d) Spleen

143. The living organisms can be unexceptionally distinguished from the non-living things on the basis of their ability for:

- a) Interaction with environment and progressive evolution
b) Reproduction

- c) Growth and movement
d) Responsive to touch
144. Parameters of old age are
a) End of reproductive phase
b) Concomitant changes in the body
c) Slowing down of vital process
d) All of the above
145. Which of the following statement is true with reference to cross pollination in angiosperms?
a) It requires the production of a large number of pollen grains
b) It can fail to occur due to distance barrier
c) It occurs only in unisexual flowers
d) It most often results in high yield of plants
146. 'In coconut the cellular endosperm surrounds the nuclear endosperm'.
The above statement is
a) True
b) False
c) Sometimes (a) and sometimes (b)
d) Neither (a) nor (b)
147. Continued self-pollination results in
a) Inbreeding depression
b) Out breeding depression
c) Hybrid vigour
d) Better result in offsprings
148. Acrosome is the modified
a) Mitochondria
b) Lysosome
c) Golgi body
d) Nucleus
149. According to which theory, ageing is due to accumulation of harmful protein?
a) Error catastrophe
b) Free radicle
c) Cross linking
d) Somatic mutation
150. Graafian follicle contains
a) Oogaonial cells
b) Corpus luteum
c) Theca externa and theca interna

d) Corpus albicans

151. Identify of A, B and C in the figure given below

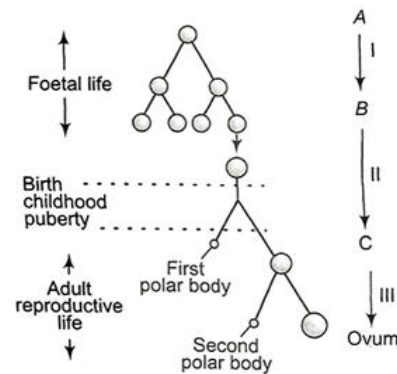

- a) A- Secondary
b) A- Oogonia, B- Primary oocyte, C- Secondary oocyte
c) A- Secondary oocyte, B- Primary oocyte, C- Primary oocyte
d) A- Oogonia, B- Secondary oocyte, C- Primary oocyte

152. Every person is Indian in world

- a) Fifth b) Sixth c) Ninth d) First

153. In male sterilization ...A... is cut and tied. This process is calledB....

Fill correct option for A and B

- a) A-vas deferens; B- tubectomy
b) A-vas deferens; B- vasectomy
c) A-vas efferentia; B- tubectomy
d) A-vas efferentia; B- vasectomy

154. A man of blood group-A marries woman of blood group-AB, which type of progeny would indicate that man is heterozygous?

- a) O b) B c) A d) AB

155. Which one of the following traits of garden pea studied by Mendel was a recessive feature?

- a) Green pod colour
b) Round seed colour
c) Axial flower position
d) Green seed colour

156. Sex chromosomes of male are

- a) Homozygous
b) Heterozygous
c) Hemizygous
d) autosomes

157. DNA is dependent on ...A... for synthesis of proteins. DNA and RNA both can function as genetic material. But ...B... being more stable, preferred for the storage of genetic information. For the transmission of genetic information, ...C... is better
Choose the correct option for A, B, and C
a) A-DNA, B-RNA, C-RNA
b) A-RNA, B-DNA, C-RNA
c) A-RNA, B-RNA, C-DNA
d) A-DNA, B-RNA, C-DNA
158. Splicing takes place in
a) Prokaryotes only b) Eukaryotes only
c) Protista only d) Plants only
159. Study of origin and development of humans in all their physical, social and cultural relationship is called
a) Zoology b) Anthropology
c) Biogeography d) Zoogeography
160. Change of frequency of alleles in a population results in evolution. This statement is proposed in
a) Darwin's theory
b) Lamarck's theory
c) Hardy -Weinberg principle
d) de Vries theory
161. Thymus is the site for the development and maturation of
a) T-lymphocyte b) B-lymphocyte
c) Both (a) and (b) d) Antibodies
162. An autoimmune disease is
a) AIDS b) Haemophilia
c) Allergy d) Myasthenia gravis
163. Infective stage of *Plasmodium* for men is
a) Merozoites b) Ookinetes
c) Sporozoites d) None of these
164. Scientists are trying to get hybridization between tomato and potato. The most accurate name of the recusant would be
a) Topato b) Topemo c) Potamo d) Pomato
165. Methods of breeding for acquiring disease resistance are
I. conventional breeding techniques
II. mutation breeding
III. radiation breeding
Chose the correct option
a) I and II b) I and III
c) I only d) III only
166. Protoplasts of two different species are used in
a) Micro-propagation
b) Somatic hybridization
c) Clonal propagation
d) Organography
167. Which one of the following is biofuel?
a) Wood b) Petroleum
c) Natural gas d) Coal
168. Which of the following is specifically used in genetic engineering?
a) Ligase
b) Gyrase
c) DNA polymerase
d) Restriction endonuclease
169. Which of the following statements are correct with respect to a bioreactor?
I. It can process small volume of culture
II. It provides optimum temperature, pH, salt, vitamins and oxygen
III. Sparged stirred-tank bioreactor is a stirred type reactor in which air is bubbled
Choose the correct option
a) I and II b) I and III
c) II and III d) I, II and III
170. Treatment of a genetic disorder by manipulating genes is called
a) Gene therapy b) Gene replacement
c) Bone marrow d) Enzyme
transplantation replacement

- therapy
171. Transgenic animals are developed by
- a) Introducing foreign genes b) Introducing gene mutations
 c) Deleting certain chromosomes parts d) Stopping spindle formation
172. Somaclonal variation appears in plants
- a) Growing in polluted soil or water
 b) Exposed to gamma rays
 c) Raised in tissue culture
 d) Transformed by recombinant DNA technology
173. When two related populations occupy geographically or spatially separate areas, they are called
- a) Allopatric population
 b) Quantum population
 c) Saltational population
 d) Parapatric population
174. Life history traits of organisms have evolved in relation to the constraints imposed by which components of habitat
- a) Organic components b) Abiotic components
 c) Biotic components d) Both (b) and (c)
175. Simplified model of phosphorus cycling in a terrestrial ecosystem is given below. Identify *A, B, C* and *D*
- a) A-Weathering, B-Decomposition, C-Consumer, D-Soil
 b) A-Decomposition, B-Weathering, C-Producer, D-Soil
 c) A-Weathering, B-Decomposition, C-

- Decomposer, D-Soil
 d) A-Decomposition, B-Decomposer, C-Weathering, D-Soil
176. Suppose 2000 J of solar energy is incident on green vegetation. On the basis of 10% law of Lindeman. Identify *A, B* and *C*
- a) A-20 J, B-2 J, C-0.2 J b) A-200 J, B-20 J, C-2 J
 c) A-400 J, B-40 J, C-4 J d) A-40 J, B-4 J, C-0.4 J
177. Communities with more species tend to be more stable than those with less species. This was confirmed by
- a) Alexander von Humboldt
 b) David Tilman
 c) Paul Ehrlich
 d) Edward Wilson
178. Which of the following hypothesis suggests, that the ecosystems are like aeroplane wings where the flight (ecosystem functional) may or may not be compromised depending upon which species are being lost
- a) Gaia hypothesis
 b) Gause-exclusion hypothesis
 c) Qudum's hypothesis
 d) Rivet popper hypothesis
179. A disease caused by eating fish contaminated by industrial waste containing mercury compounds is known as
- a) Bright's disease b) Minamata disease
 c) Hashimoto disease d) Osteosclerosis
180. Term used for accumulation of non-degradable pollutant in higher trophic level is
- a) Biomagnification b) Eutrophication
 c) Biome d) Ecotone

